

DESCRIPTION  
 S-SHOP SHIP  
 D-DROP SHIP  
 W-WITH ASS'Y.

# BILL OF MATERIAL

SHIPPING LIST							DESCRIPTION & REMARKS	
MFG. CTR.	ITEM MK. NO.	NO. REQ'D.	UNITS	HS	PART NO.	COMP. CODE		
	SBD	1	1	PCS	S	400006	461	SB STACK 24" DIA THRU THE WALL
			1	PCS	W	400296	461	SB STACK 24" DIA 90 DEG ELBOW W/ FLANGES EACH END W/ (8) 7/16" DIA HOLES ON 25 13/16" DIA B. C. FLANGE HOLE PATTERN
			1	PCS	W	400297	461	SB STACK 24" DIA STRAIGHT WELDED STACK W/ (1) FLANGE W/ (8) 7/16" DIA HOLES ON 25 13/16" DIA B.C. FLANGE HOLE PATTERN & W/ (1) FLANGE SHIPPED LOOSE (NO BOLT HOLES) W/ SHOP PROVIDED BIRD SCREEN TACK WELDED IN PLACE
			1	PCS	W	400298	461	SB STACK 24" DIA 18 GA ALUMZ'D FLAT FLASHING
			20	PCS	W	149996	461	FSTNR SCREW HH .375-16 X 1. ZN PLT GR 2
			10	PCS	W	127725	461	FSTNR SCREW CARRIAGE .375-16 X 1. ZN PLT
			30	PCS	W	30066	461	FSTNR NUT HEX .375-16 ZN PL
			30	PCS	W	33520	461	FSTNR WSH FLAT .375 ZN PL
			1	TUBE	W	68996	461	CMPD CAULKING ACRYLIC LATEX 10.1-OZ WHITE
								HMS 130B #850A - 12 PER CASE

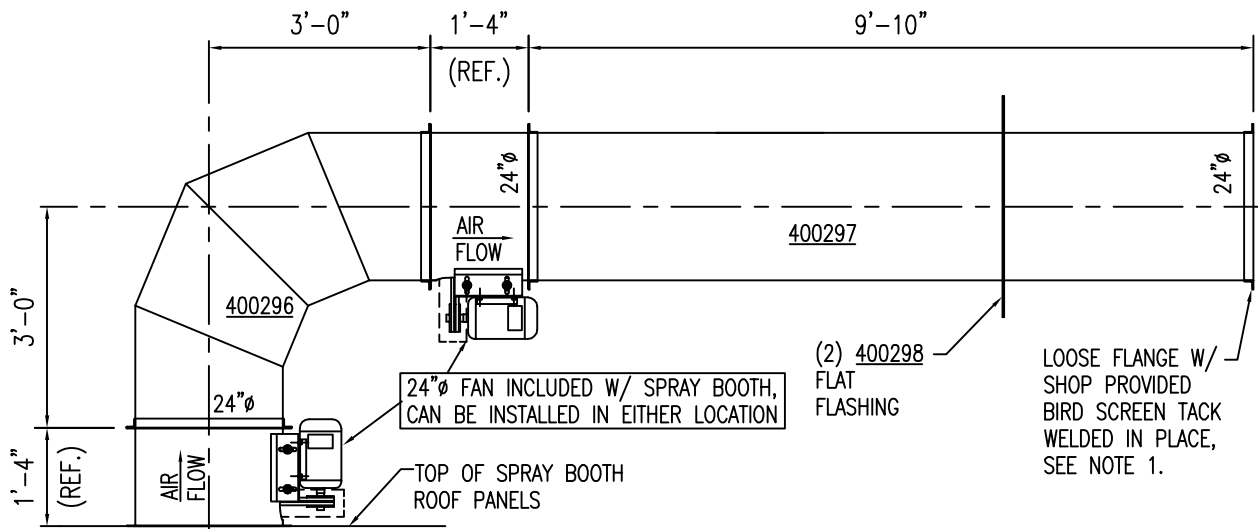

**NOTES:**

- 24"Ø STRAIGHT STACK DUCTWORK (#400297) CAN BE CUT TO LENGTH REQUIRED. LOOSE FLANGE W/ BIRD SCREEN IS TACK WELDED TO DUCT. BREAK WELDS AND FIELD CUT DUCT TO LENGTH REQUIRED. GRIND END OF DUCT SO THAT IT IS FREE OF ANY BURRS AND STITCH WELD FLANGE TO DUCTWORK 1" WELD LG ON 3" CENTERS.

GEORGE KOCH SONS, LLC  
 EVANSVILLE, IN 47744



SPRAY BOOTH STACK 24" DIA THRU THE WALL

ASSEMBLY AND BILL OF MATERIAL

Date 11/7/07

Part No. 400006

Sketch No. 1 OF 1

This drawing and its designs are part of the intellectual property of GEORGE KOCH SONS, LLC. and may not be copied or used without the written permission of GEORGE KOCH SONS, LLC. This drawing, its designs and any information hereon may not be disclosed to any third party without the written permission of GEORGE KOCH SONS, LLC.

Rev No.

Revision Description